

# KEYSTONE **STANDARD**<sup>®</sup> DESIGN CHARTS

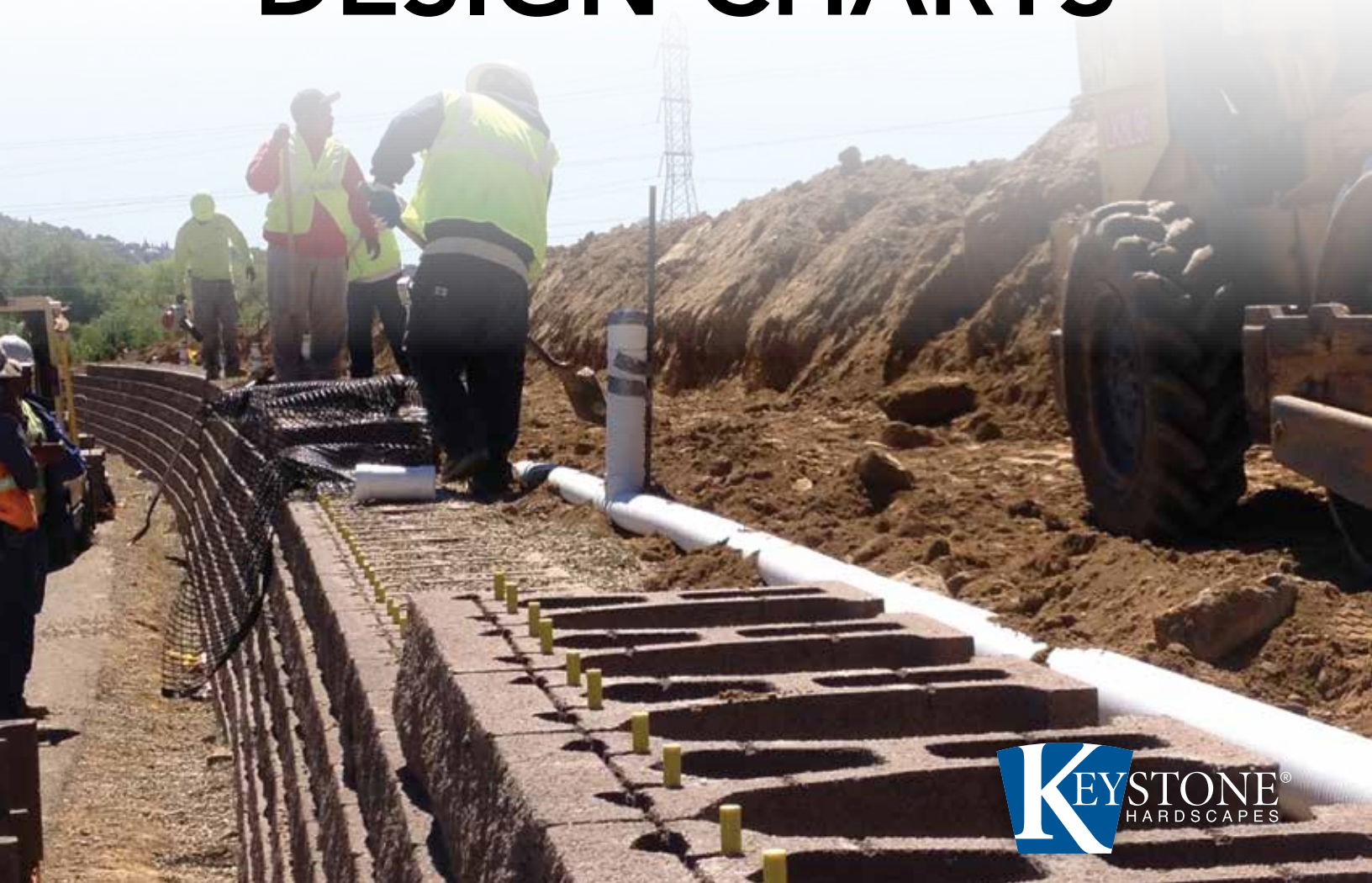



# DESIGN/ESTIMATING CHARTS

---

**T**his section contains Keystone design/estimating charts for Keystone Standard unit series III gravity walls or geogrid reinforced walls.

The gravity wall charts help determine the maximum possible gravity wall height for a Keystone Standard unit. First, select which unit will be used for the wall. Second, determine which soil type most closely represents the soil conditions on the project site. Finally, select the backslope condition that most closely represents the final constructed wall condition.

The reinforced wall charts consider multiple factors for determining the necessary geogrid length. First, select the appropriate unit type and wall batter. Next, determine the wall load condition that most closely resembles the final project conditions. Then select the soil condition that most closely matches the project site soils. Finally, select the wall height (including embedment) that will best fit the project wall profile.

The design/estimating charts in this section are to be used for reference and preliminary design use only. These charts are not to be considered as a standardized engineering document. A qualified professional should be consulted for final design assistance. Keystone accepts no liability for the use of these charts.



## GRAVITY WALL SCHEMATIC

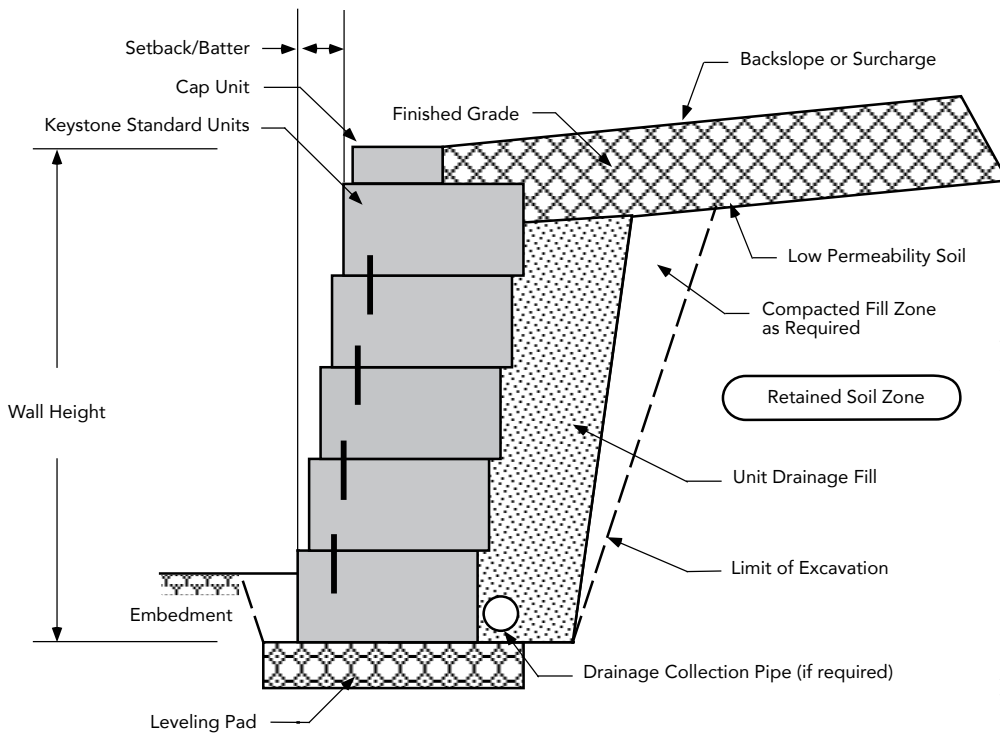

### NOTES:

Wall Height (H) is the total height from top to bottom.

Minimum wall embedment is 6 inches (150mm) or Height/8, whichever is greater for level toe.

Subsurface soils must be capable of supporting wall system

Unit drainage fill is ¾ inch (20mm) clean crushed stone.

Leveling pad is crushed stone base material.

All backfill materials are compacted to 95% Standard Proctor Density or 92% Modified Proctor Density.

Finished grade must provide positive drainage.

The information contained herein has been compiled by Keystone® Retaining Wall Systems LLC and to the best of our knowledge, accurately represents the Keystone product use in the applications which are illustrated. Final determination of the suitability for the use contemplated and its manner of use are the sole responsibility of the user. Structural design and analysis shall be performed by a qualified engineer.

# Maximum Height Gravity Wall Charts

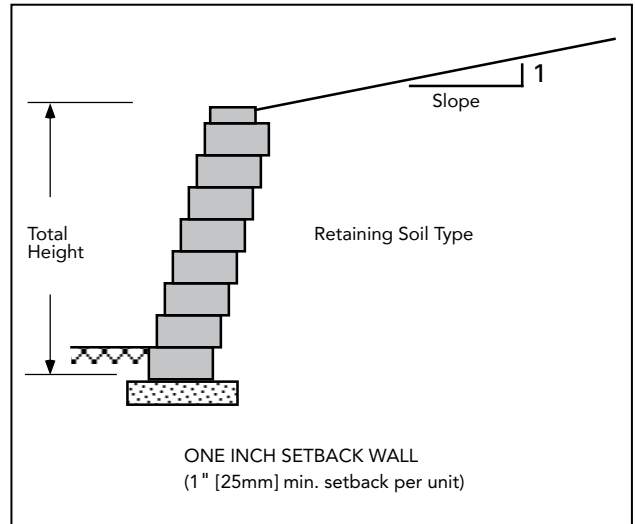
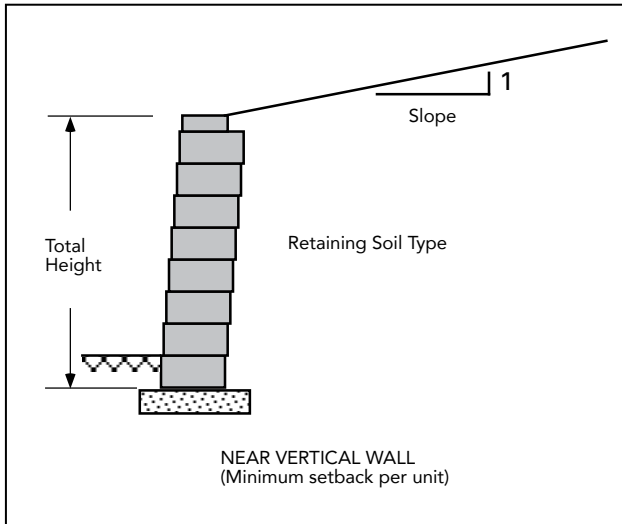

NEAR VERTICAL - KEYSTONE STANDARD UNITS-18" (457mm)

MAX. HGT.	BACKSLOPE			
	Level	4H:1V	3H:1V	2H:1V
Soil Type				
Sand/Gravel	4.33' (1.30m)	3.67' (1.10m)	3.67' (1.10m)	3.00' (0.91m)
Silty Sand	3.67' (1.10m)	3.00' (0.91m)	3.00' (0.91m)	3.00' (0.91m)
Silt/Lean Clay	3.67' (1.10m)	3.00' (0.91m)	3.00' (0.91m)	<1.00' (0.30m)

SETBACK OPTION - KEYSTONE STANDARD UNITS-18" (457mm)

MAX. HGT.	BACKSLOPE			
	Level	4H:1V	3H:1V	2H:1V
Soil Type				
Sand/Gravel	5.67' (1.70m)	5.00' (1.50m)	5.00' (1.50m)	4.33' (1.30m)
Silty Sand	5.00' (1.50m)	4.33' (1.30m)	4.33' (1.30m)	3.67' (1.10m)
Silt/Lean Clay	4.33' (1.30m)	3.67' (1.10m)	3.00' (0.91m)	2.33' (0.71m)

NEAR VERTICAL - KEYSTONE STANDARD UNITS-21" (533mm)

MAX. HGT.	BACKSLOPE			
	Level	4H:1V	3H:1V	2H:1V
Soil Type				
Sand/Gravel	5.00' (1.50m)	4.33' (1.30m)	4.33' (1.30m)	3.67' (1.10m)
Silty Sand	4.33' (1.30m)	3.67' (1.10m)	3.67' (1.10m)	3.00' (0.91m)
Silt/Lean Clay	3.67' (1.10m)	3.67' (1.10m)	3.00' (0.91m)	2.33' (0.71m)

SETBACK OPTION - KEYSTONE STANDARD UNITS-21" (533mm)

MAX. HGT.	BACKSLOPE			
	Level	4H:1V	3H:1V	2H:1V
Soil Type				
Sand/Gravel	7.00' (2.10m)	6.33' (1.90m)	5.67' (1.70m)	5.00' (1.50m)
Silty Sand	5.67' (1.70m)	5.00' (1.50m)	5.00' (1.50m)	4.33' (1.30m)
Silt/Lean Clay	5.00' (1.50m)	4.33' (1.30m)	3.67' (1.10m)	3.00' (0.91m)

**NOTES:**

Calculations assume a unit weight of 120 Pcf (19kN/M<sup>2</sup>) for all soil types. Assumed  $\phi$  angles for earth pressure calculations are: Sand/Gravel=34°, Silty Sand=30°, and Sandy Silt/Lean Clay=26°. Non critical structures with FS>1.5. Gravity wall charts are performed using coulomb earth pressure analysis. (NCMA 3rd Edition) Near vertical walls utilize 1° batter and 1" setback wall utilize 8° batter. No surcharges were used in the analysis. Surcharges or special loading conditions will reduce maximum wall heights. Sliding calculations assume a 6" (150mm) crushed stone leveling pad as compacted foundation material. The information provided is for preliminary design use only. A qualified professional should be consulted. Keystone accepts no liability for the use of these tables.

# Design/Estimating Charts: Reinforced Wall Charts Notes



The Keystone reinforced wall charts are graphically presented to show the proper location and lengths of geogrids used with Keystone Standard units at the near vertical and 1 inch (25mm) setback batter (8°). Design heights were set in two block increments beginning at 4.3 feet (1.3m) and ending 11 feet (3.4m). Engineering judgement should be used when interpolating between heights. In general, geogrid should be placed at the design elevation for the entire wall length or until a wall step is reached. Minimum reinforcement lengths were set for 5 feet (1.5m) and a 70% reinforcement length to wall height ratio. Always use the same vertical spacing of geogrid throughout the wall. If your maximum height of wall requires 3 units vertical spacing, then use that spacing even though lower wall heights in the charts may indicate 4 units. Top layers of geogrid shall never be more than 3 units from the top of the wall. Bottom layers of geogrid shall never be more than 3 units from the top of the leveling pad. Insert a geogrid layer at these locations where 3 unit courses are exceeded. 250 psf surcharge is applied 6 inches behind the tail of the units. Soil ranges were selected to approximate good, medium and poor soil conditions to cover the typical design range. Wall height is the total height of the wall from the top of the leveling pad to the top of the wall.

The charts use Rankine earth pressure for calculations. The following charts assume the use of a coated polyester geogrid with a minimum allowable design strength of: LTDS=1800 plf (26.3 kN/m) Tal=1200 plf (17.5 kN/m). The following geogrid types are suitable with these design charts:

- » Synteen SF35 by Synteen
- » Miragrid 3XT by TC Mirafi
- » Stratagrid 200 by Strata Systems
- » 55/30-20 by Huesker Inc.

All geogrid lengths shown are the actual lengths of geogrid required as measured from the front wall face to the end of the geogrid. The charts assume that the walls are constructed in accordance with Keystone specifications and good construction practice. All soil zones (reinforced, retained, and foundation) must be compacted in 8 inch (200mm) lifts to 95% Standard Proctor density or 92% Modified Proctor Density as determined by laboratory testing. The information contained in the design/estimating charts are for preliminary design use only. A qualified professional should be consulted for final design assistance. Keystone accepts no liability for the use of these charts.

## REINFORCED WALL SCHEMATIC

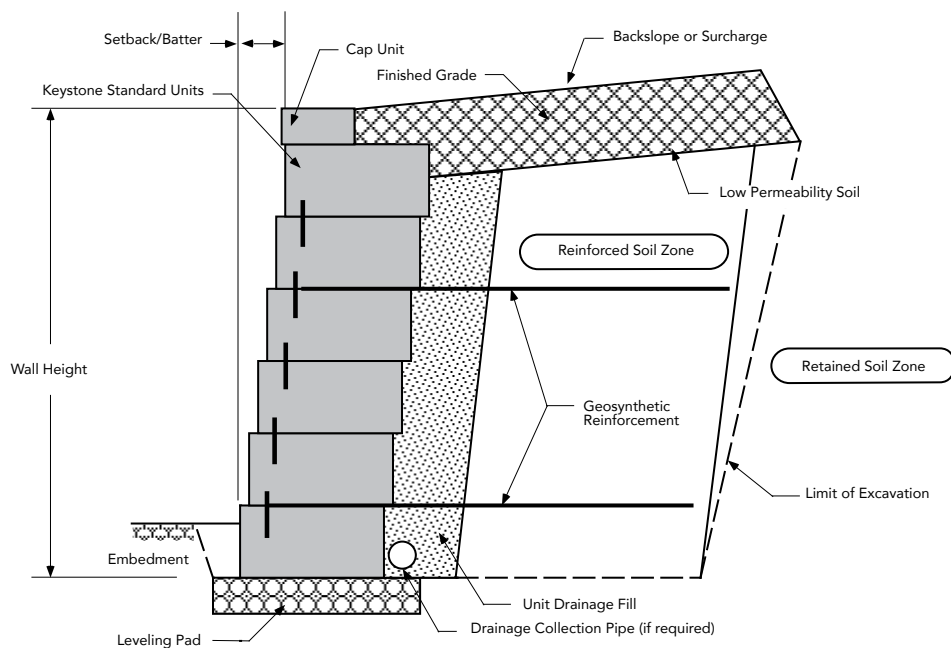

### NOTES:

Wall Height (H) is the total height from top to bottom.

Minimum wall embedment is 6 inches (150mm) or Height/20, whichever is greater for level toe.

Subsurface soils must be capable of supporting wall system.

Unit drainage fill is ¾ inch (20mm) clean crushed stone.

Leveling pad is crushed stone base material.

All backfill materials are compacted to 95% Standard Proctor density or 92% Modified Proctor density.

Geogrids must be of appropriate type and length per the design.

Finished grade must provide positive drainage.

The symbol  $\left(5'\right)$  indicates location and length of geogrid measured from the front of wall to the end of the geogrid.

The information contained herein has been compiled by Keystone® Retaining Wall Systems LLC and to the best of our knowledge, accurately represents the Keystone product use in the applications which are illustrated. Final determination of the suitability for the use contemplated and its manner of use are the sole responsibility of the user. Structural design and analysis shall be performed by a qualified engineer.

# Design/Estimating Charts: Reinforced Wall Charts

## KEYSTONE STANDARD UNITS - 1" (25mm) SET BACK

SAND/GRAVEL:  $\phi=34^\circ$ ,  $\gamma=120$  pcf ( $19\text{kN/m}^3$ )

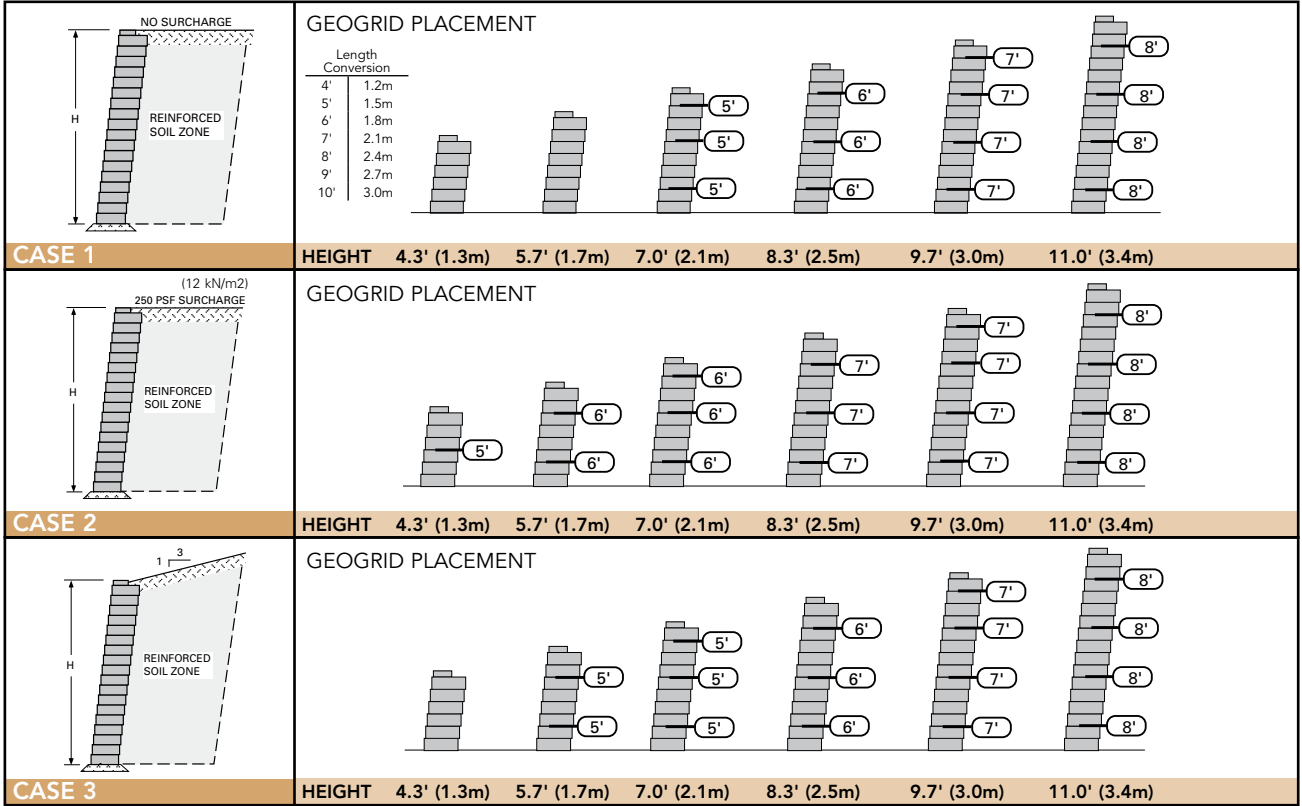

## KEYSTONE STANDARD UNITS - 1" (25mm) SET BACK

SILTY SAND:  $\phi=30^\circ$ ,  $\gamma=120$  pcf ( $19\text{kN/m}^3$ )

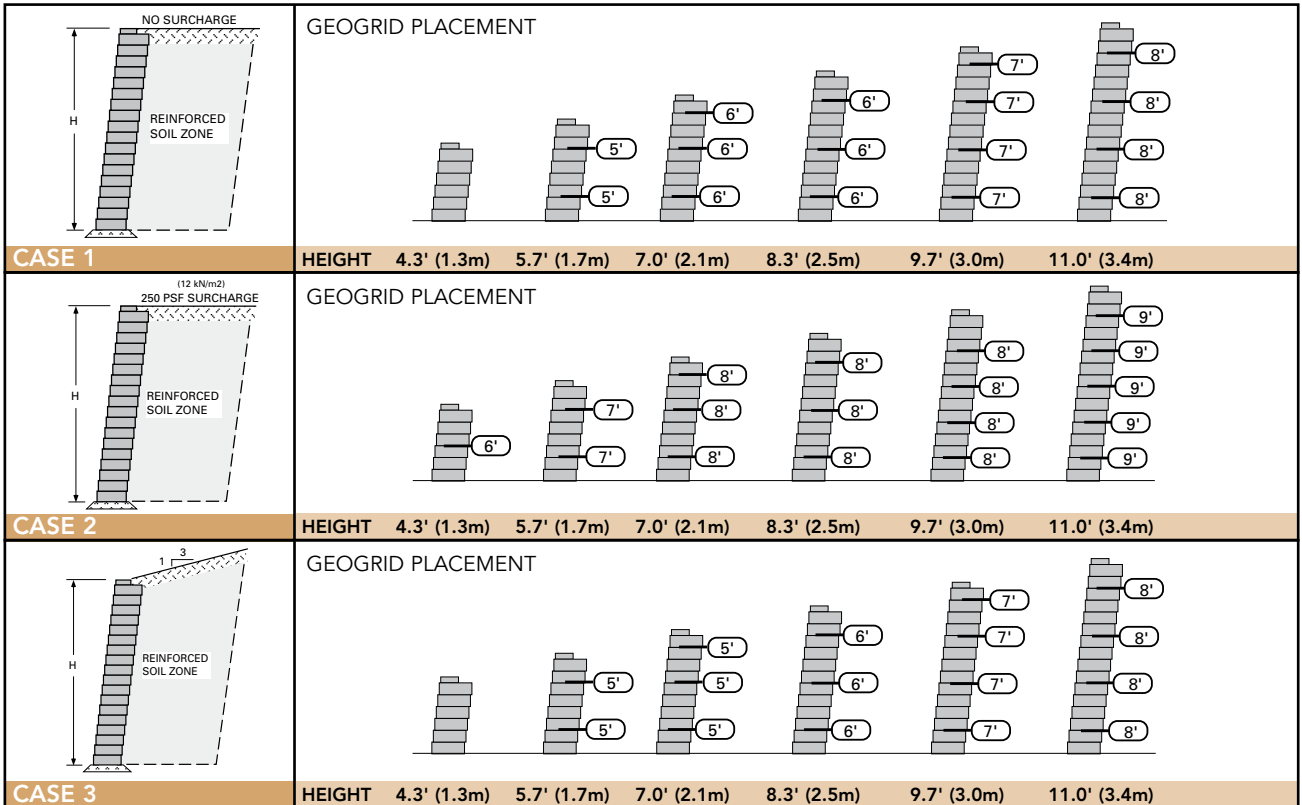

The information contained herein has been compiled by Keystone® Retaining Wall Systems LLC and to the best of our knowledge, accurately represents the Keystone product use in the applications which are illustrated. Final determination of the suitability for the use contemplated and its manner of use are the sole responsibility of the user. Structural design and analysis shall be performed by a qualified engineer.

# Design/Estimating Charts: Reinforced Wall Charts



KEYSTONE STANDARD UNITS - 1" (25mm) SET BACK

SILT/LEAN CLAY:  $\phi=26^\circ$ ,  $\gamma=120$  pcf (19kN/m<sup>3</sup>)

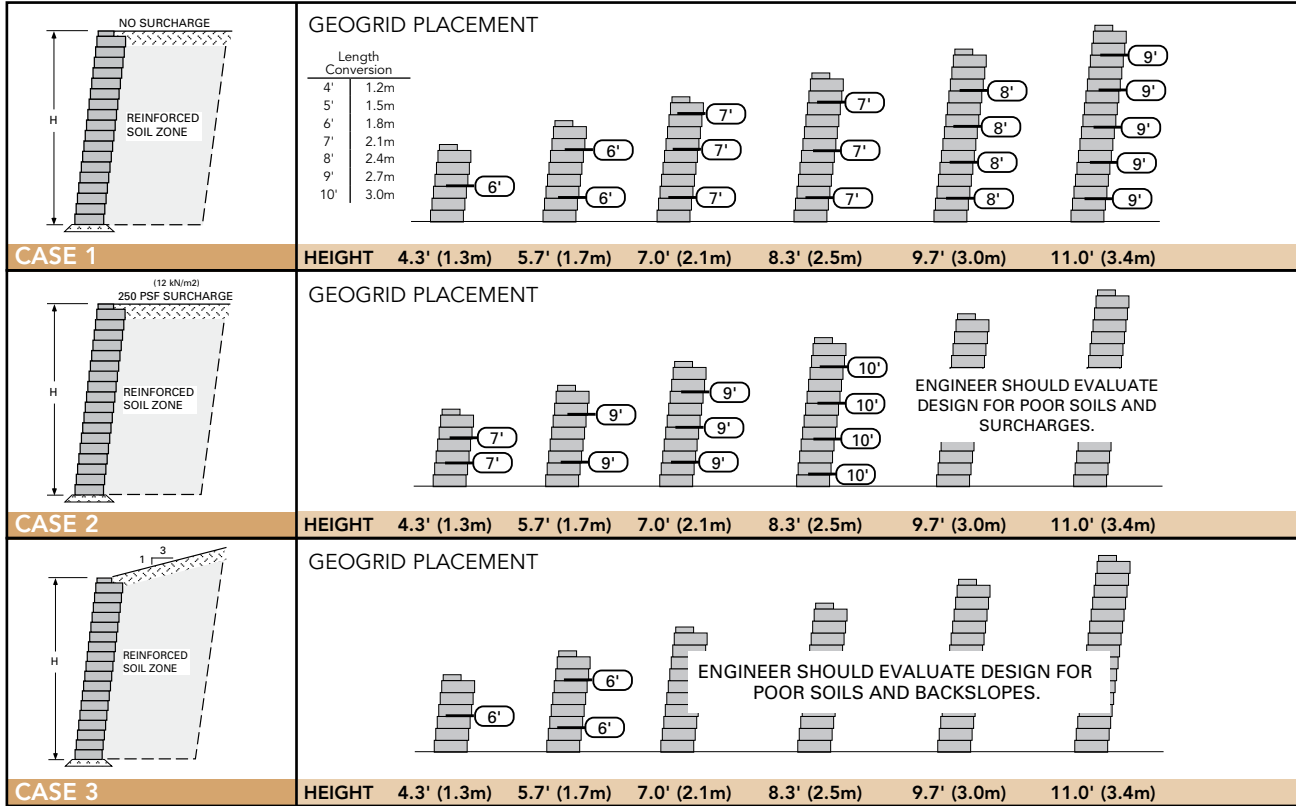

KEYSTONE STANDARD UNITS - NEAR VERTICAL

SAND/GRAVEL:  $\phi=34^\circ$ ,  $\gamma=120$  pcf (19kN/m<sup>3</sup>)

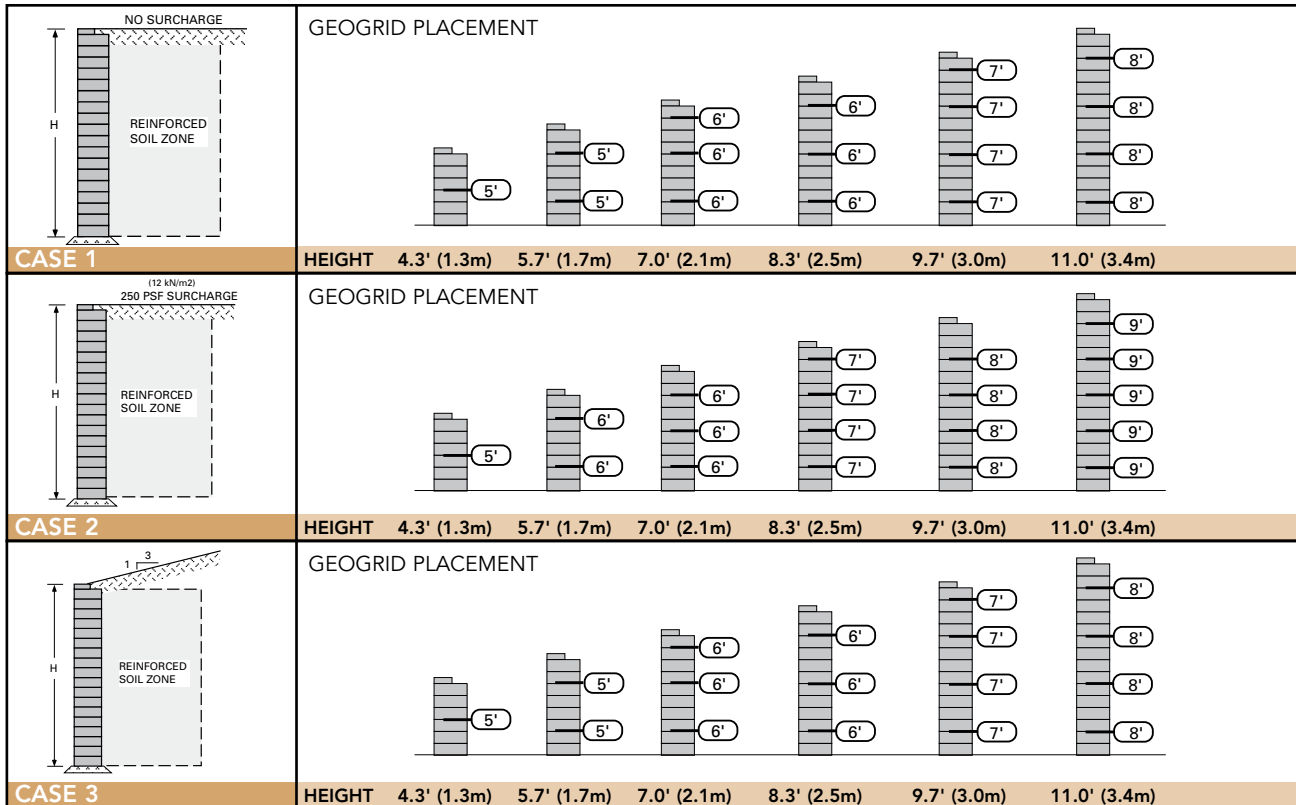

The information contained herein has been compiled by Keystone® Retaining Wall Systems LLC and to the best of our knowledge, accurately represents the Keystone product use in the applications which are illustrated. Final determination of the suitability for the use contemplated and its manner of use are the sole responsibility of the user. Structural design and analysis shall be performed by a qualified engineer.

# Design/Estimating Charts: Reinforced Wall Charts

## KEYSTONE STANDARD UNITS - NEAR VERTICAL

SILTY SAND:  $\phi=30^\circ$ ,  $\gamma=120$  pcf (19kN/m<sup>3</sup>)

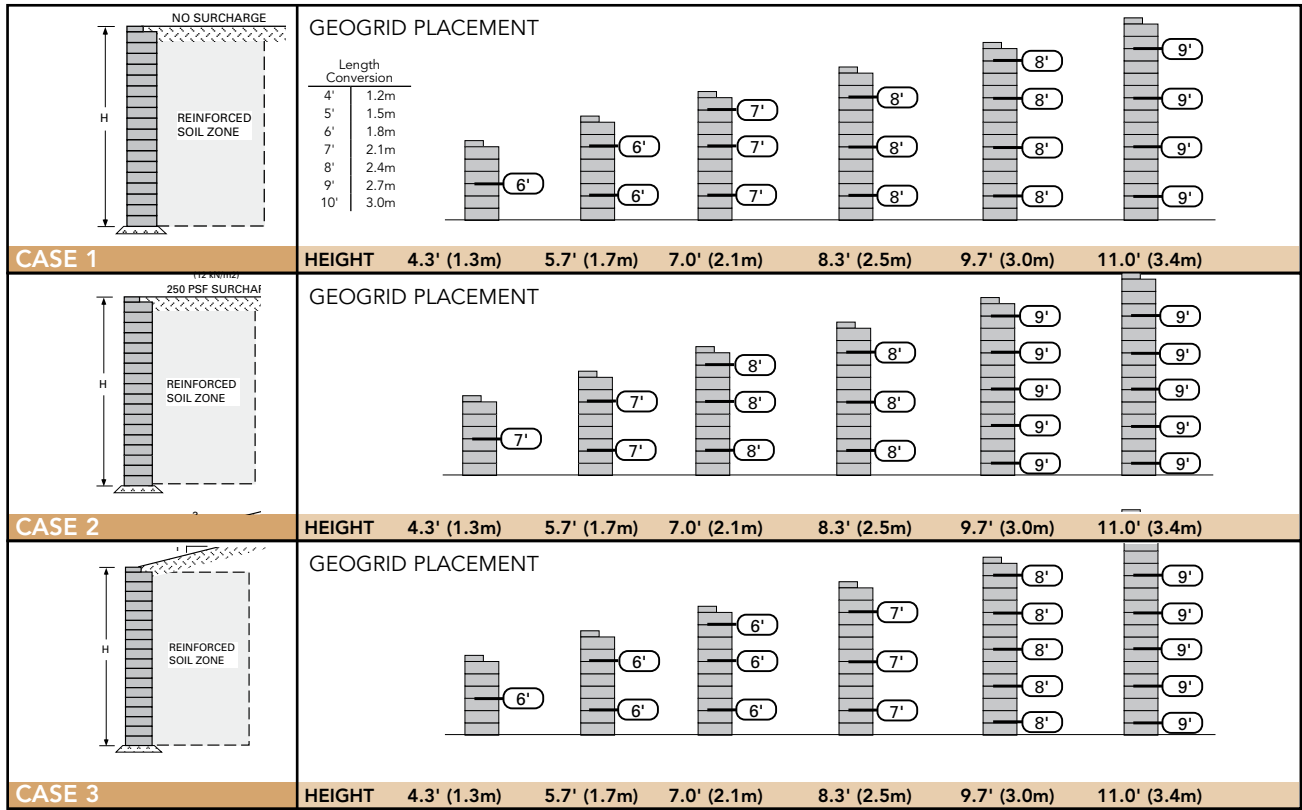

## KEYSTONE STANDARD UNITS - NEAR VERTICAL

SILTY/LEAN CLAY:  $\phi=26^\circ$ ,  $\gamma=120$  pcf (19kN/m<sup>3</sup>)

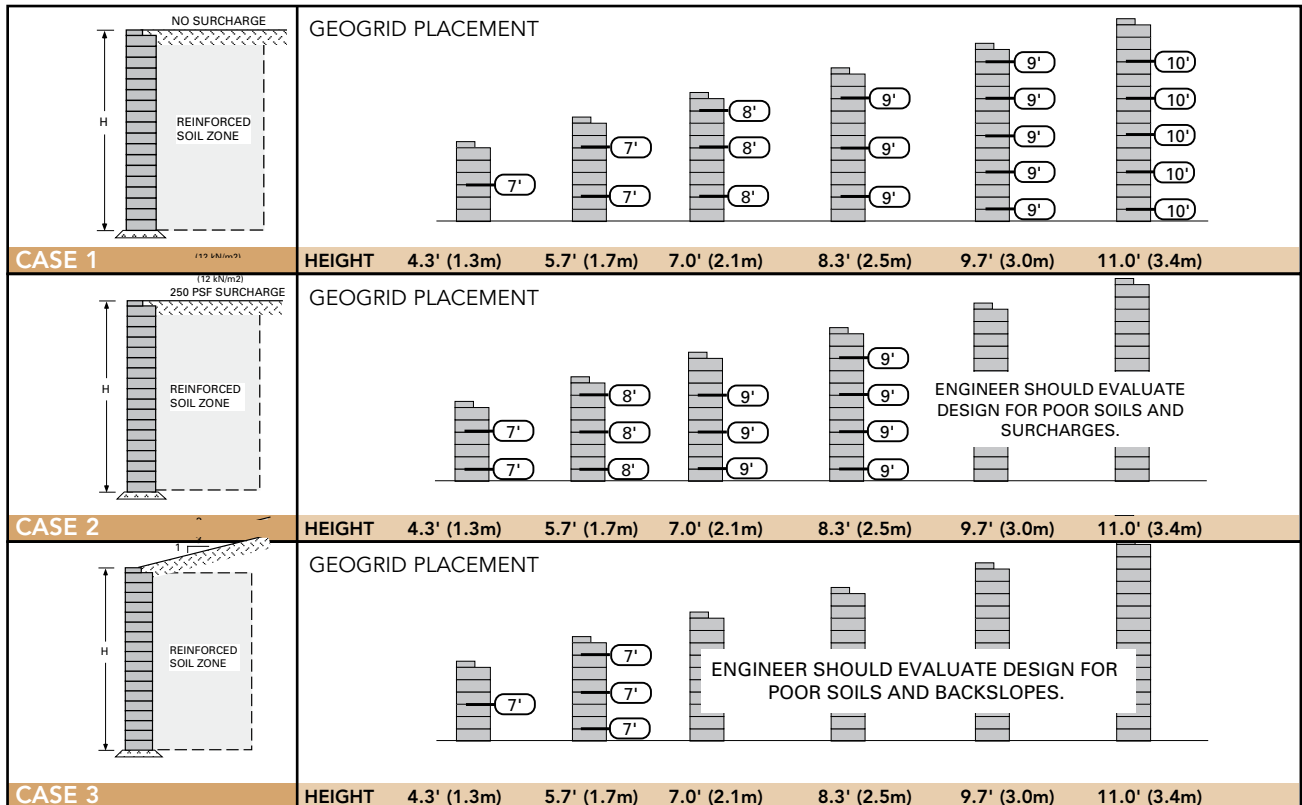

The information contained herein has been compiled by Keystone® Retaining Wall Systems LLC and to the best of our knowledge, accurately represents the Keystone product use in the applications which are illustrated. Final determination of the suitability for the use contemplated and its manner of use are the sole responsibility of the user. Structural design and analysis shall be performed by a qualified engineer.